

# The Protector HybridPro

Duplex pump efficiency and performance, whether there's power or not



Optimized for use with

The Protector EcoPower  
The world's most efficient sump pump

## Quick Set-Up Guide

SERIAL # \_\_\_\_\_

Basement Flood  
**Protector** inc.

Lake Zurich, IL 60047

[www.floodnot.com](http://www.floodnot.com)

847-438-6770

# QUICK SET-UP GUIDE

## **ATTENTION:**

*Refer to Instruction Manual for complete details and safety information.*

The Protector HybridPro automatic sump pump control system can be operated in three different configurations.

**IDENTIFY YOUR CONFIGURATION FROM THE FOLLOWING CHOICES AND REFER TO THE APPROPRIATE FIGURE FOR INSTALLATION:**

***FOLLOW STEPS 1 THRU 5 IN SEQUENCE.***

### **SINGLE PUMP CONFIGURATION**

See Figure 1 - Page 3

### **DOUBLE “PARALLEL” PUMP CONFIGURATION**

See Figure 2 – Page 4

### **DOUBLE “STAGGERED” PUMP CONFIGURATION**

See Figure 3 – Page 5

# FIGURE 1 - SINGLE PUMP CONFIGURATION

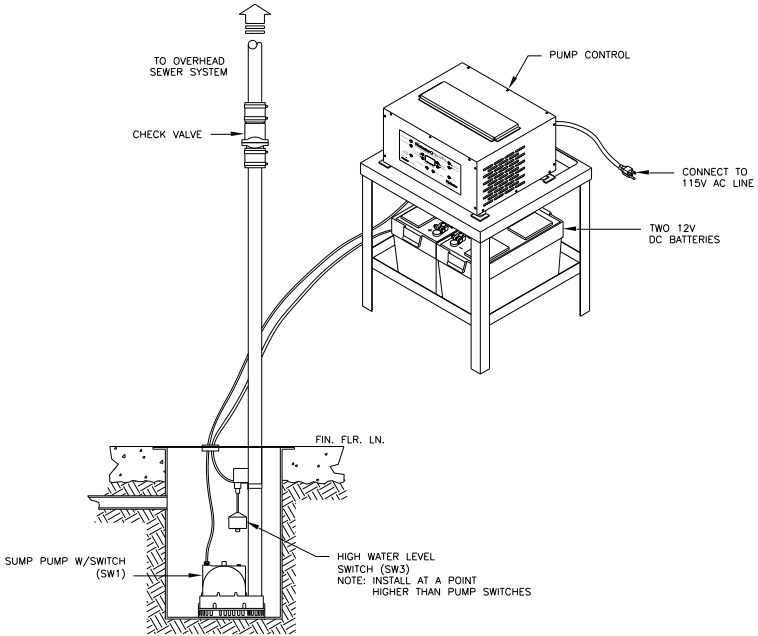

## STEP 1 - Set switch.

## STEP 2 - Connect pump, switches, & jumper cables.

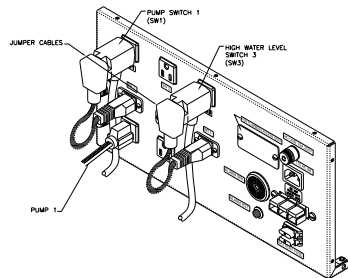
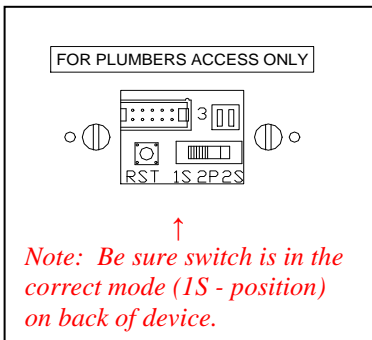

Please continue to page 6 Steps 3 thru 5

## FIGURE 2 - DOUBLE "PARALLEL" PUMP CONFIGURATION

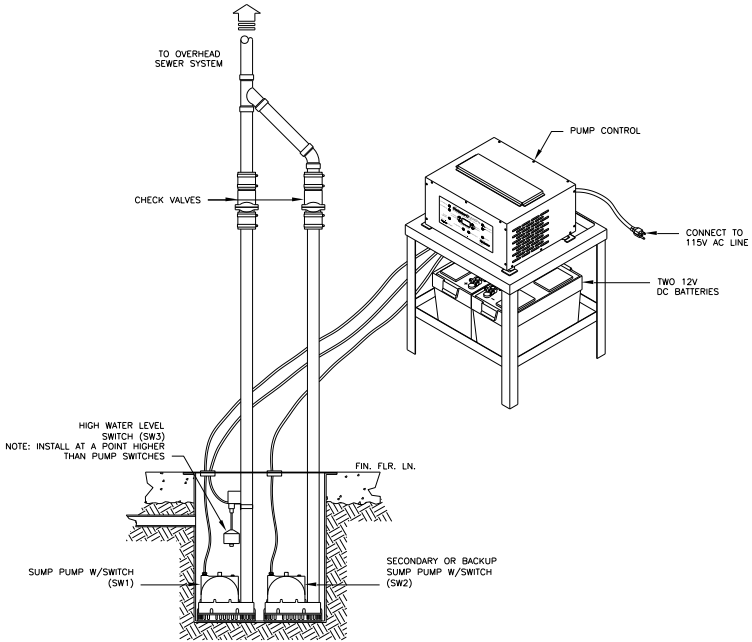

### STEP 1 - Set switch.

### STEP 2 - Connect pump, switches, & jumper cables.

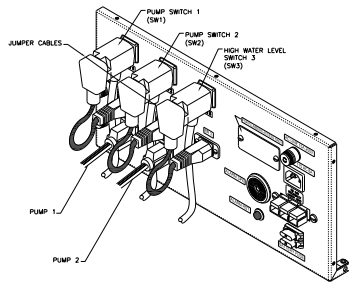
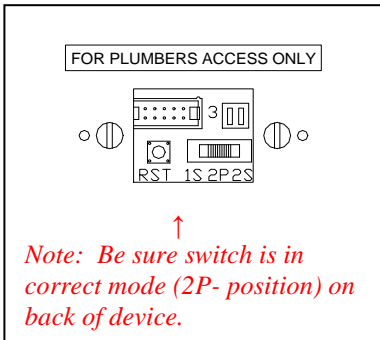

*Please continue to page 6 for Steps 3 thru 5.*

## FIGURE 3 - DOUBLE PUMP “STAGGERED” CONFIGURATION

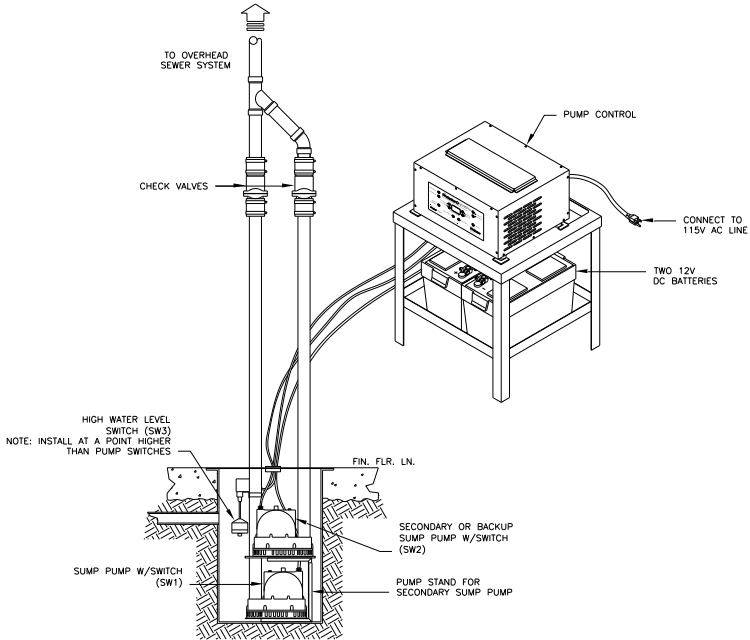

**NOTE: SW2 MUST ACTIVATE BEFORE SW3**

### STEP 1 - Set switch.

### STEP 2 - Connect pumps, switches, & jumper cables.

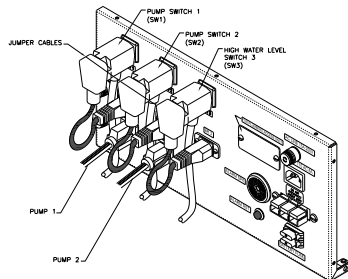
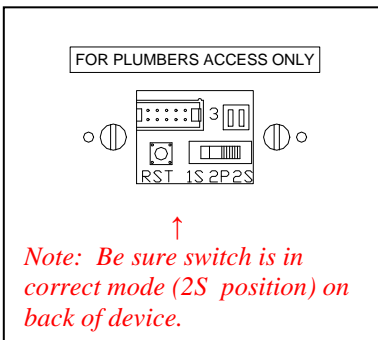

*Please continue to page 6 for Steps 3 thru 5.*

### STEP 3 - Connect batteries as shown.

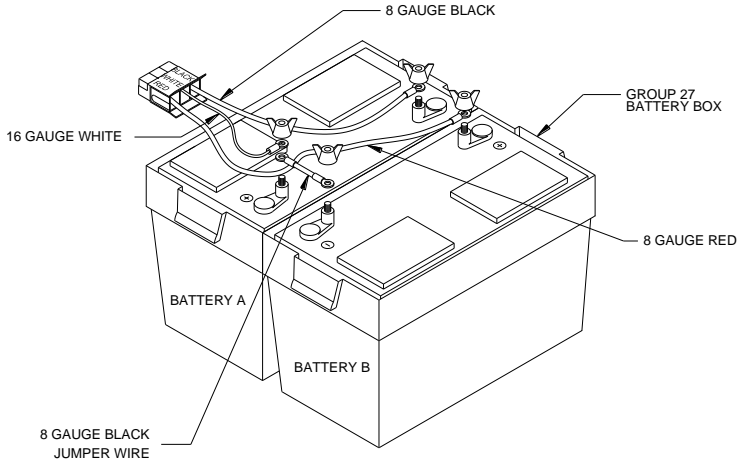

### STEP 4 - Plug battery connector into back of unit.

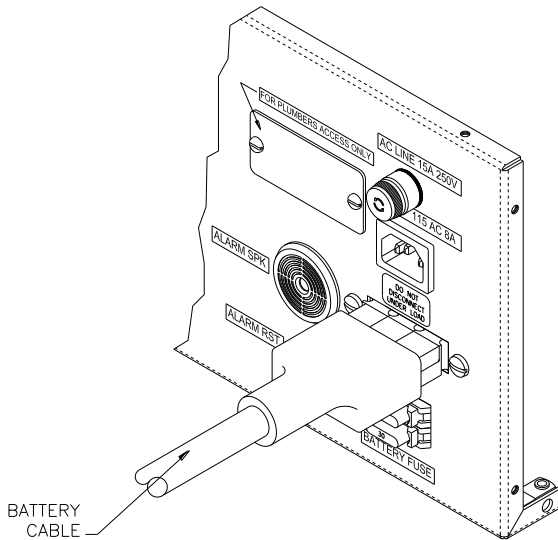

DC POWER yellow LED should light up and digital voltmeter should indicate total series battery voltage (usually in the range of 22V-26V).

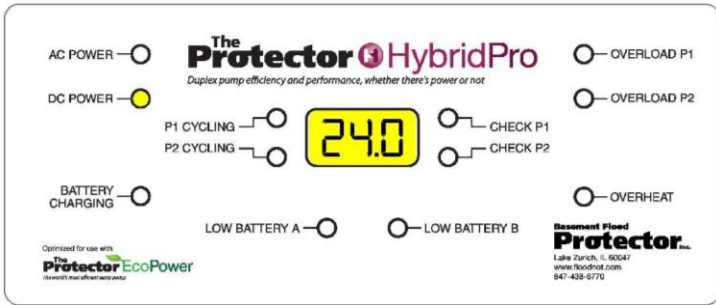

**STEP 5** - Plug the ac cord into the back of unit. Plug into wall receptacle.

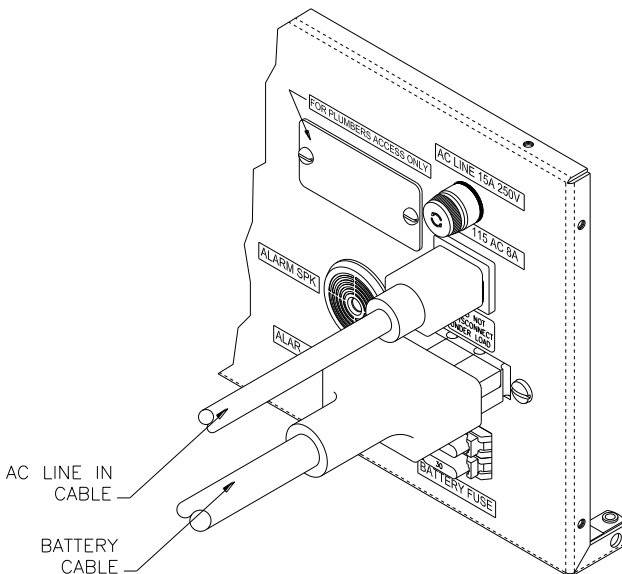

AC POWER and BATTERY CHARGING GREEN LED's should be on.

*Digital voltage meter will indicate rising battery voltage.*

*Battery charging LED will turn off when batteries are fully charged.*

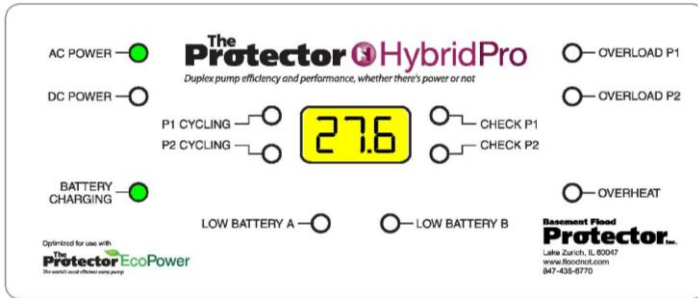

***NOTE: Refer to Instruction Manual for Additional Information.***

## ATTENTION

Contact seller for service in case of any failure. Attempts to repair unit by unauthorized personnel could result in damage to unit, injury, and/or the voiding of warranty.

## TESTING THE PUMPS & PUMP SWITCHES (SINGLE, DOUBLE “PARALLEL”, AND DOUBLE “STAGGERED”)

Connect the Protector HybridPro as shown on the appropriate page of the Quick Set-Up Guide.

Set the mode switch in the appropriate position:

CONFIGURATION	MODE SWITCH POSITION	PAGE
SINGLE PUMP	1S	3
DOUBLE “PARALLEL”	2P	4
DOUBLE”STAGGERED”	2S	5

The Mode Switch is behind the plumber access panel on the rear of the Protector HybridPro. Use a small slotted screw driver to remove one of the two screws. Pivot the access panel upward. Re-secure the access panel after the testing procedure(s).

Place the Protector HybridPro on a flat level surface, allowing access to the front and the rear of the unit.

**CAUTION: Do not over-fill the sump pit during testing!**

*For any pump cycling failure, refer to troubleshooting section of instruction manual.*

### **AFTER TESTING:**

***If the Protector HybridPro is to be wall mounted, ensure that all cabling is firmly secured after mounting the unit to the wall.***

The Protector HybridPro must be tested with the AC power disconnected and the DC power (battery source) connected. This will confirm that pumps of the proper rating are adequately supplied in the event of a power outage.

It is also recommended that the Protector HybridPro be tested with the AC and DC power connected. This will help test the normal operation sequences of the Protector HybridPro.

<b>AC POWER DISCONNECTED TEST</b>	
<b>1</b>	Disconnect the AC power supply from the Protector HybridPro to simulate a power interruption. The “DC Power” LED on the front of the Protector HybridPro will be lit.
<b>2</b>	Slowly add water to the sump pit until the pump switch 1 (SW 1) activates the pump. The appropriate “Pump cycling” LED indicator on the front of the Protector HybridPro will be lit. Allow pump to finish cycling.
<b>FOR SINGLE PUMP CONFIGURATION SKIP TO # 10</b>	
<b>FOR STAGGERED PUMP CONFIGURATIONS SKIP TO # 4</b>	
<b>PARALLEL PUMP CONFIGURATION</b>	
<b>3</b>	NOTE: When using the DC power source in Double “Parallel” pump mode, the only pump that will cycle is the pump connected to the pump 1 position on the lower left rear of the Protector HybridPro.  To test the secondary pump (pump 2) disconnect the primary pump from the pump 1 position and connect the secondary pump to the pump 1 position. Test as described in step #2
<b>SKIP TO STEP # 9</b>	
<b>STAGGERED PUMP CONFIGURATION</b>	
<b>4</b>	To test the secondary pump (pump 2), disconnect pump switch 1 (SW1) from the rear of the Protector HybridPro.
<b>5</b>	Repeat step #2 for pump switch 2 (SW2) The warning alarm will sound. The appropriate LED on the front of the Protector HybridPro will be lit. Allow the secondary pump to finish cycling.
<b>6</b>	To silence the warning alarm, depress the round pushbutton switch on the lower right of the rear side of the Protector HybridPro.
<b>7</b>	To reset the flashing “check pump 1” indicator on the front of the Protector HybridPro, depress the small reset button that is located behind the plumber access panel on the rear of the Protector HybridPro.
<b>8</b>	Reconnect pump switch 1 (SW1) to the rear of the Protector HybridPro. The primary pump (pump 1) will activate and complete the evacuation.
<b>9</b>	Reconnect the pump(s) to their original position(s).
<b>10</b>	Reconnect the Protector HybridPro to the AC power supply.

<b>AC POWER CONNECTED TEST</b>	
<i>To test parallel pump disconnect switch 1 (SW1) in rear of Protector HybridPro</i>	
<b>1</b>	Slowly add water to the sump pit until the pump switch activates the pump. The appropriate “pump cycling” LED indicator on the front of the Protector HybridPro will be lit. (Primary pumps will cycle based on position of cycle count select switch located in plumbers access on rear of Protector HybridPro before secondary pump cycles).
<b>PARALLEL PUMP CONFIGURATION SKIP TO #3</b>	
<b>STAGGERED PUMP CONFIGURATION SKIP TO #6</b>	
<b>2</b>	After cycling, disconnect the pump switch from the rear side of the Protector HybridPro.
<b>FOR SINGLE PUMP CONFIGURATION SKIP TO # 9</b>	
<b>PARALLEL PUMP CONFIGURATION</b>	
<b>3</b>	Reconnect pump switch 1 (SW1) and disconnect pump switch 2 (SW2) from the rear side of the Protector HybridPro.
<b>4</b>	Repeat step #1.
<b>5</b>	Disconnect pump switch 1 (SW1) and leave pump switch 2 (SW2) disconnected. <b>CAUTION: Both pumps are now disabled!</b>
<b>SKIP TO #9</b>	
<b>STAGGERED PUMP CONFIGURATION</b>	
<b>6</b>	Repeat step #1, several times until the primary pump is bypassed and pump switch 2 (SW2) activates pump 2. The secondary pump (pump 2) will cycle.
<b>7</b>	When the secondary pump completes its cycle, the primary pump will activate and complete the evacuation.
<b>8</b>	To test the high water level switch 3 (SW3) disconnect pump switch 2 (SW2). Simulate several pumping events as described in Step 1. The primary pump (pump1) and the secondary pump (pump 2) will be passed on the last event.
<b>9</b>	Repeat step #1. The warning alarm will sound and the appropriate “check pump(s)” LED indicator on the front panel of the Protector HybridPro will flash.
<b>10</b>	To reset the flashing “check pump” indicator on the front of the Protector HybridPro, depress the small reset button that is located behind the plumber access panel on the rear of the Protector HybridPro.
<b>11</b>	To silence the warning alarm, depress the round pushbutton switch on the lower right of the rear side of the Protector HybridPro.
<b>12</b>	Reconnect pump switch to the rear of the Protector HybridPro. (In Parallel pumps reconnect pump switch 1 & 2 to start cycle)

